

**Notes:**  
**GENERAL**  
 - Drawings, areas and dimensions are indicative only, contractor is responsible for a full measured site survey. All dimension provided should be checked on site and should not be exceeded. **DO NOT SCALE DRAWING.**  
 - All construction to be carried out in accordance with all the relevant current Health and safety guidelines and regulations.  
 - Engineer to be consulted if existing construction differs from those shown on drawings.  
 - All materials and fixings to be installed fully in accordance with manufacturers recommendations.  
 - Fixings, connectors and plates to be galvanised  
 - Min. tensile strength of coach screws and bolts  $f_u=400N/mm^2$   
 - Toothed-plate connectors should comply with BS EN 912 and BS EN 14545  
 - Drawing to be read in conjunction with PIC107-2021-CE-19, PIC107-2022-CE-20 and PIC107-2022-CE-21

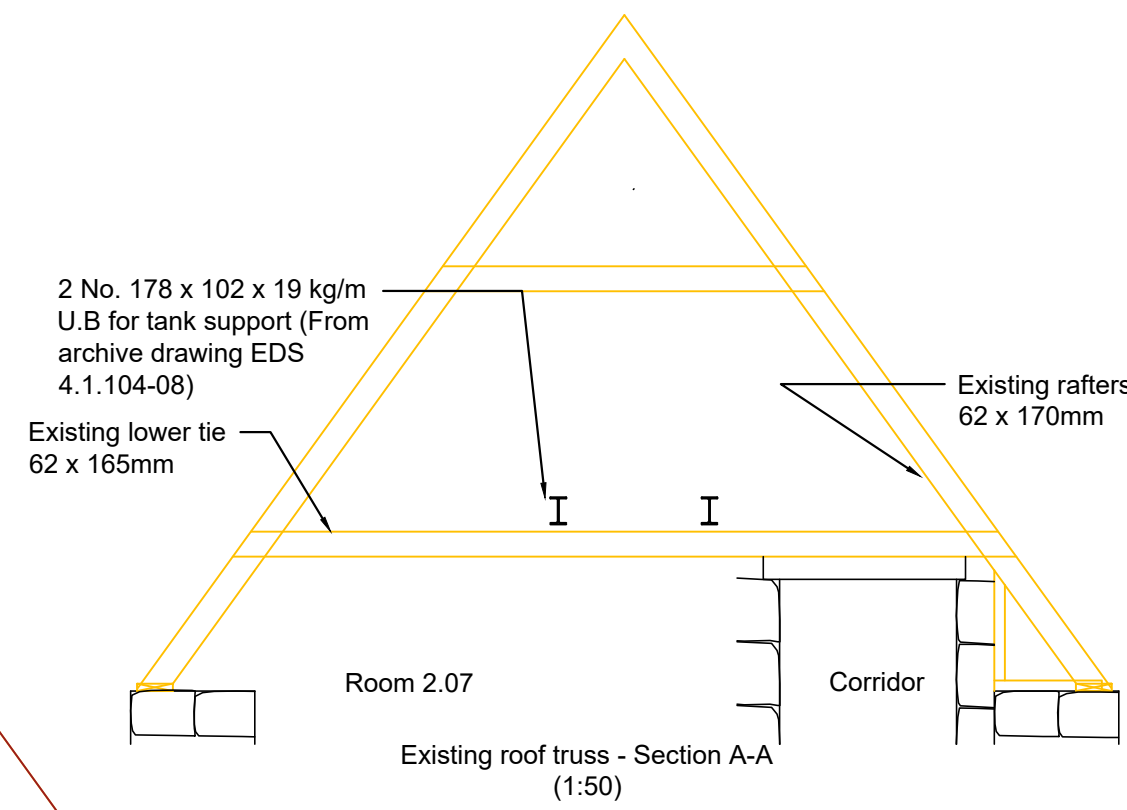

- Methodology**
1. New temporary tie 62x165mm to be installed above existing (approx. 600mm above) as shown with red dashed lines. Connection of tie to rafter as per Detail 1
  2. Existing tie to be removed as a whole and set aside. Tie to be examined for signs of rot at its ends. Ceiling is probably supported off tie in Room 2.07. To be ascertained if this is the case as plaster ceiling will have to be locally removed to allow for tie removal
  3. Rotten part of rafter to be removed and new timber piece to be installed butted against existing and notched in as in Detail 2. Prop rafter on each side of the rotten timber prior to removing it. Props to continue to first floor level (Similar propping arrangement as for lintels replacement-Drawing PIC107-2022-CE-21)
  4. New splice steel plates to be installed along rafter as shown in Detail 3 on sound timber. Ensure centre of new bolts to be at least 100mm from end of rotten timber section of rafter
  5. If timber tie is in good condition with no signs of rot, to be re-instated and connected to rafter on RHS as per Detail 5 and to LHS as per Detail 1. If timber is rotten at ends, replace it with same size timber Grade C24
  6. Temporary tie can be removed

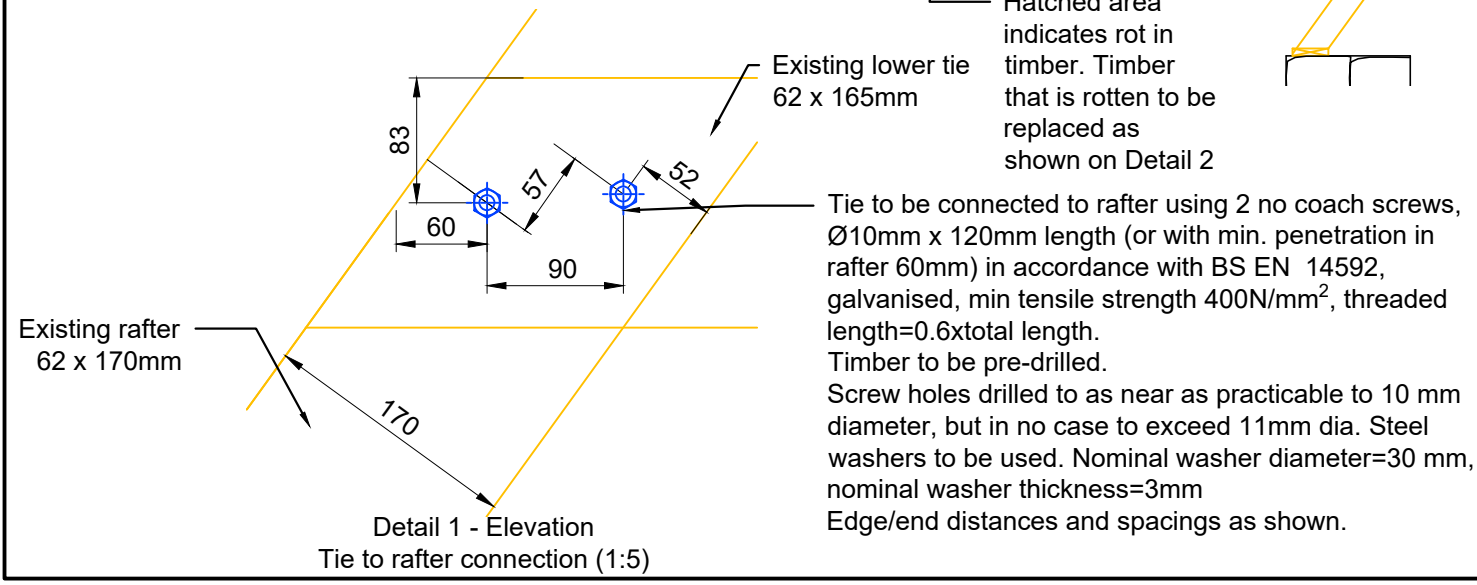
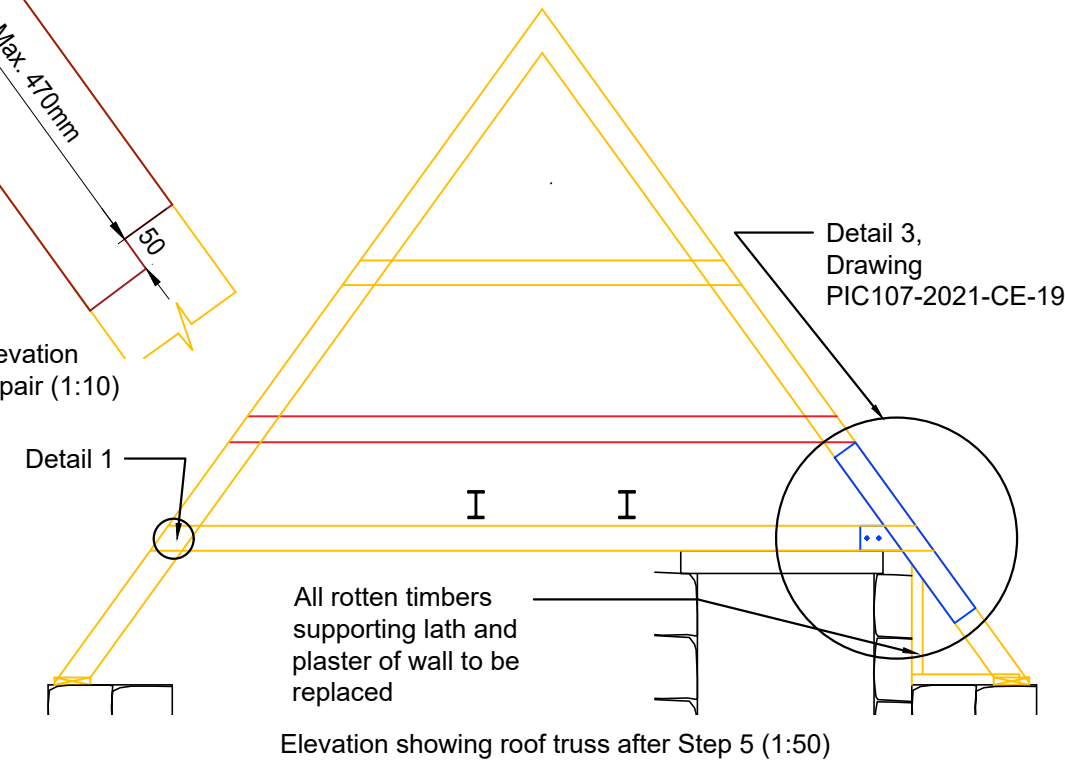
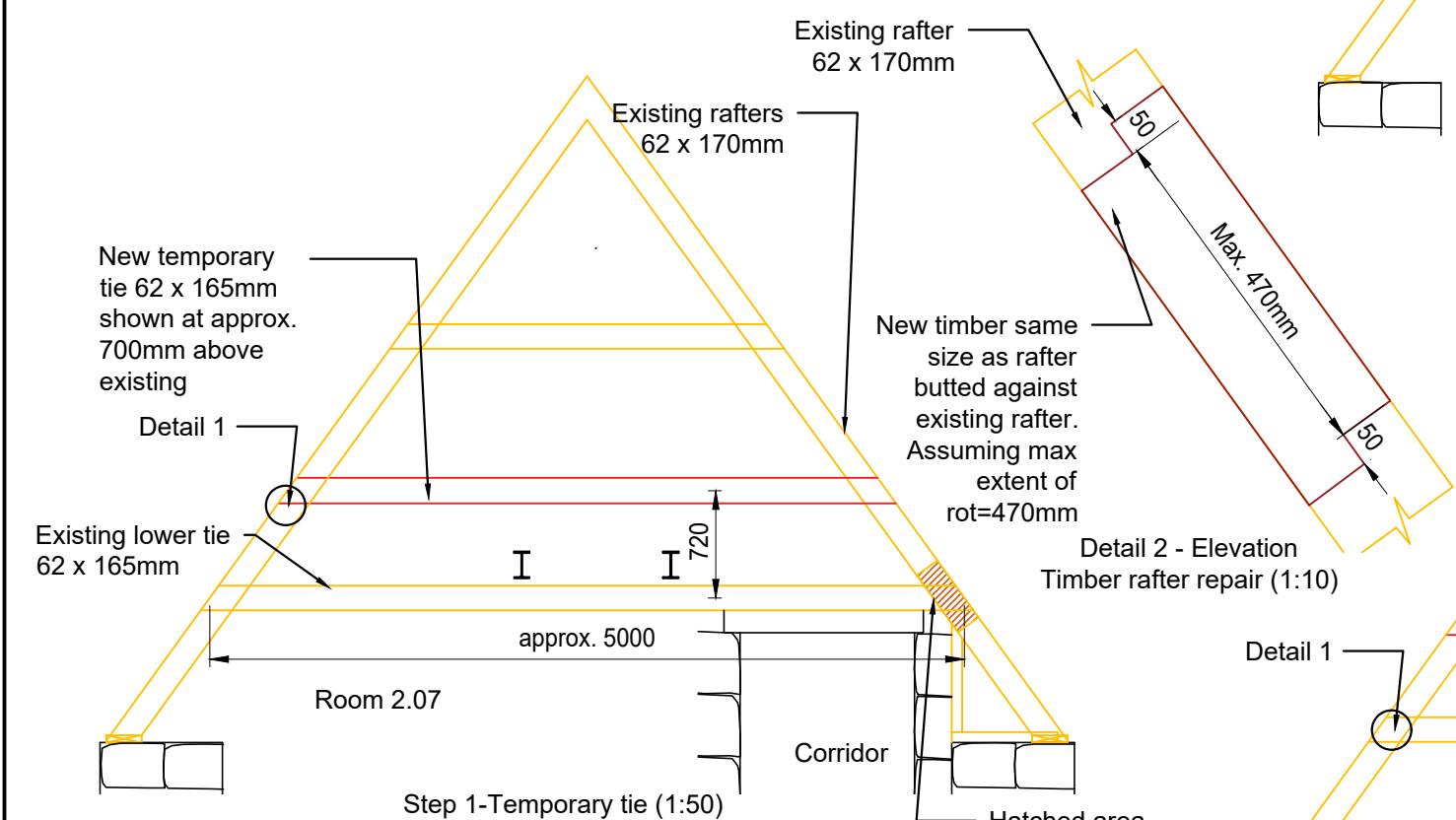

- Residual Risks**
1. Manual handling of steel plates and timber tie
  2. Working in tight space with existing services
  3. Welding - To be done off site

Revisions:  
 Rev.A-03/03/2022-FN-Notes amended



MONUMENT	ARGYLL'S LODGING
PROJECT	Corridor 2.05 and Room 2.07
Repairs to lower tie and rafter of roof truss-Methodology	



PROJECT DRAWING NUMBER		PIC107-2021-CE-18A	
SCALE	As shown @ A3	Engineer	F Nanopoulou
DATE	13/10/2021	DRAWN BY	FN
ARCHIVE NUMBER			