

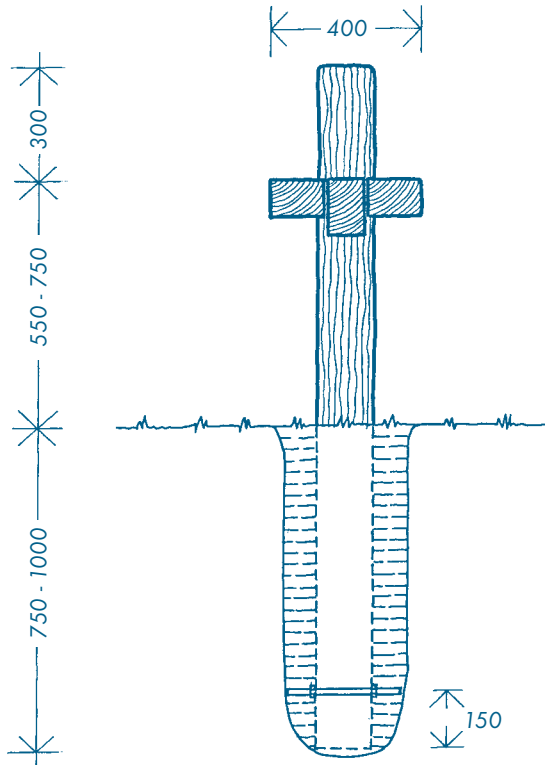

7.2A Front End View

Scale 1:20



7.2B Side Elevation

Scale 1:20

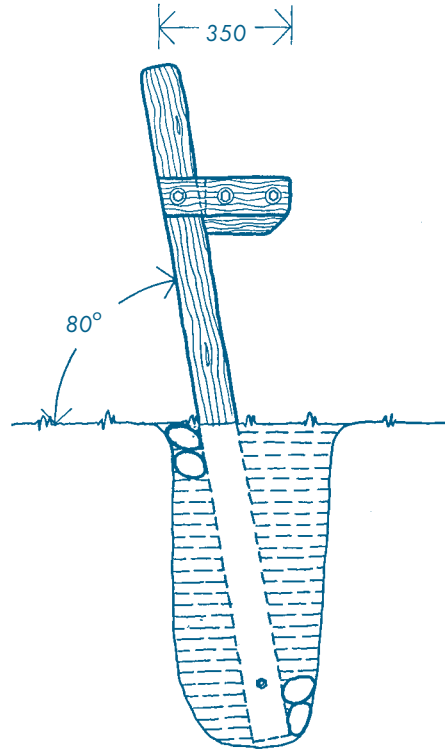

7.2C Side Elevation (Detail)

Scale 1:5

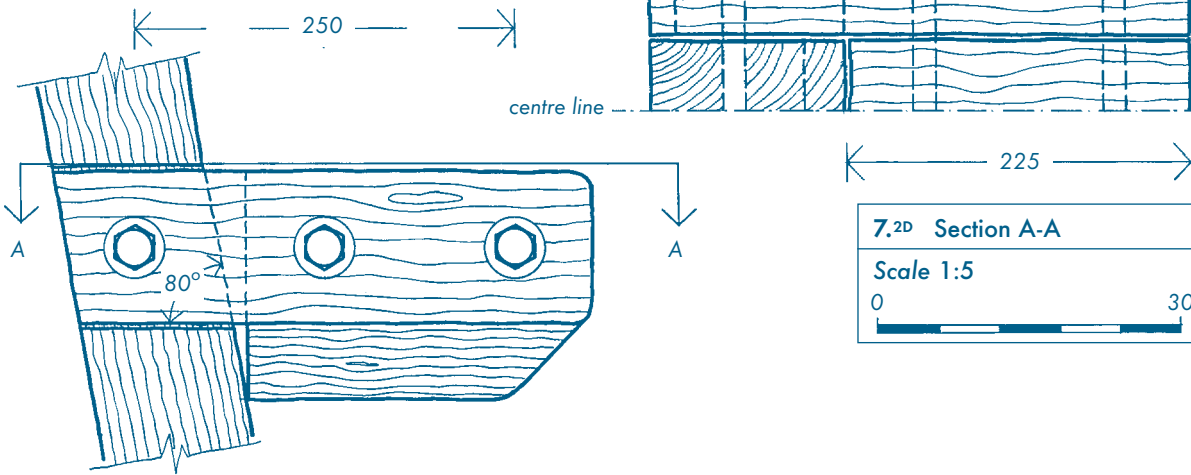

7.2D Section A-A

Scale 1:5



