

Note:

- Extent of concrete to be determined on site by contractor
- All concrete and grout works to be carried out under controlled conditions to prevent any contaminants from seeping into river
- SEPA to be notified immediately if contaminants are found to have entered the river

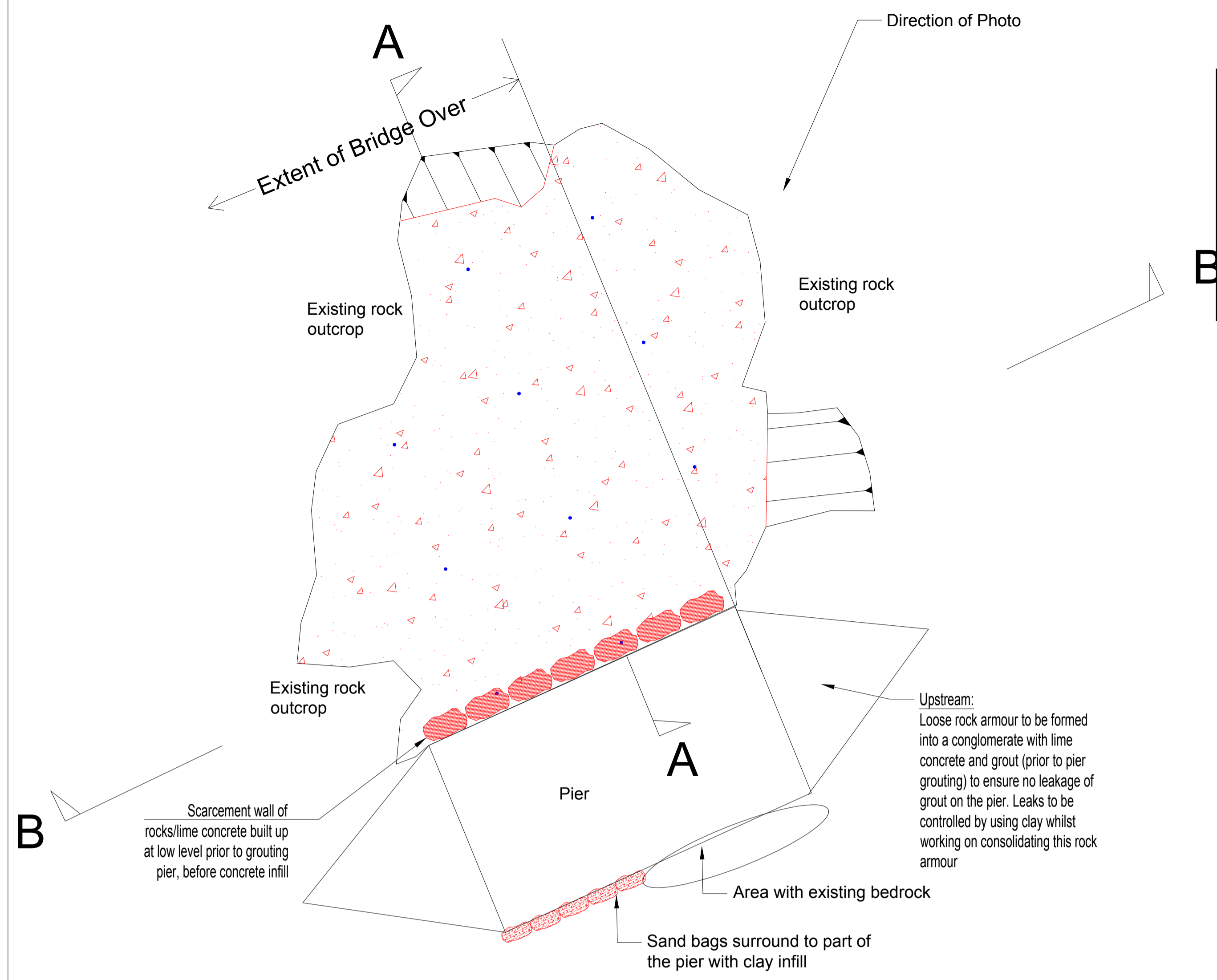

Plan (1:50)

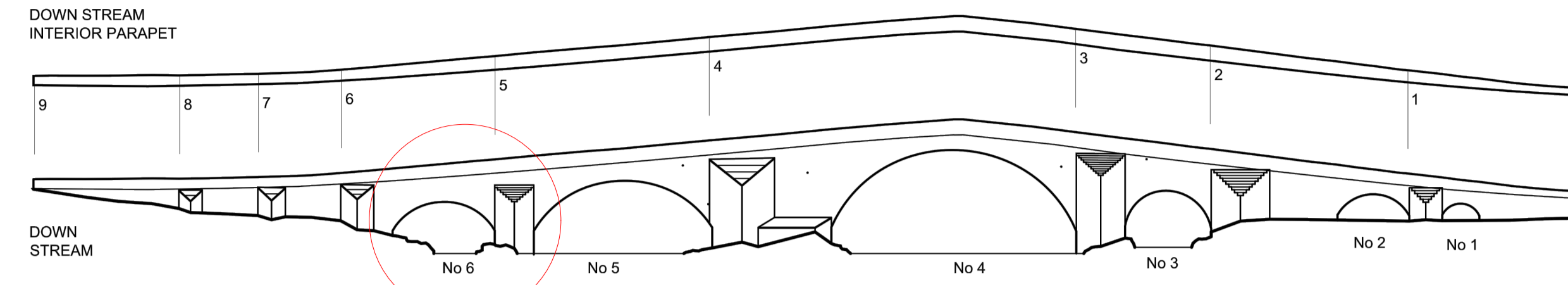

Location of Infill (NTS)



General view of area to be infilled (NTS)

Methodology:

1. Clear site from any debris / vegetation.
2. Divert water from entering beneath pier using concrete / sand bags and clay.
3. Place sand bags around pier (on riverside) with clay infill as shown in detail.
4. Form existing loose rock in upstream into a conglomerate with lime concrete and grout to ensure no leakage while grouting the pier. Leaks to be controlled using clay whilst working on this armour.
5. Build a scarcement wall of rocks and lime concrete at low level under the arch against the pier as shown in detail.
6. Pump coloured dye (water based) beneath pier ensuring there is no leakage into river. Use clay to seal any joints.
7. Once all joints are sealed use lime concrete to infill the base of the pier.
8. Use Heritage Grout 7 to consolidate the upper section of pier. Allow to set.
9. Pump any water out from the infill area.
10. Install dowels as shown with min 600mm embedment into rock.
11. Place A393 mesh with 75mm top cover and tie into dowels.
12. Pump C30 concrete mix (self levelling and/or underwater concrete may be required) into area ensuring no leakage into river (it is anticipated that the concrete truck and pump would sit on the bridge).
13. Level concrete if required and allow to cure.
14. Install cobbels over concrete area to match those beneath arches to the north end of the bridge.

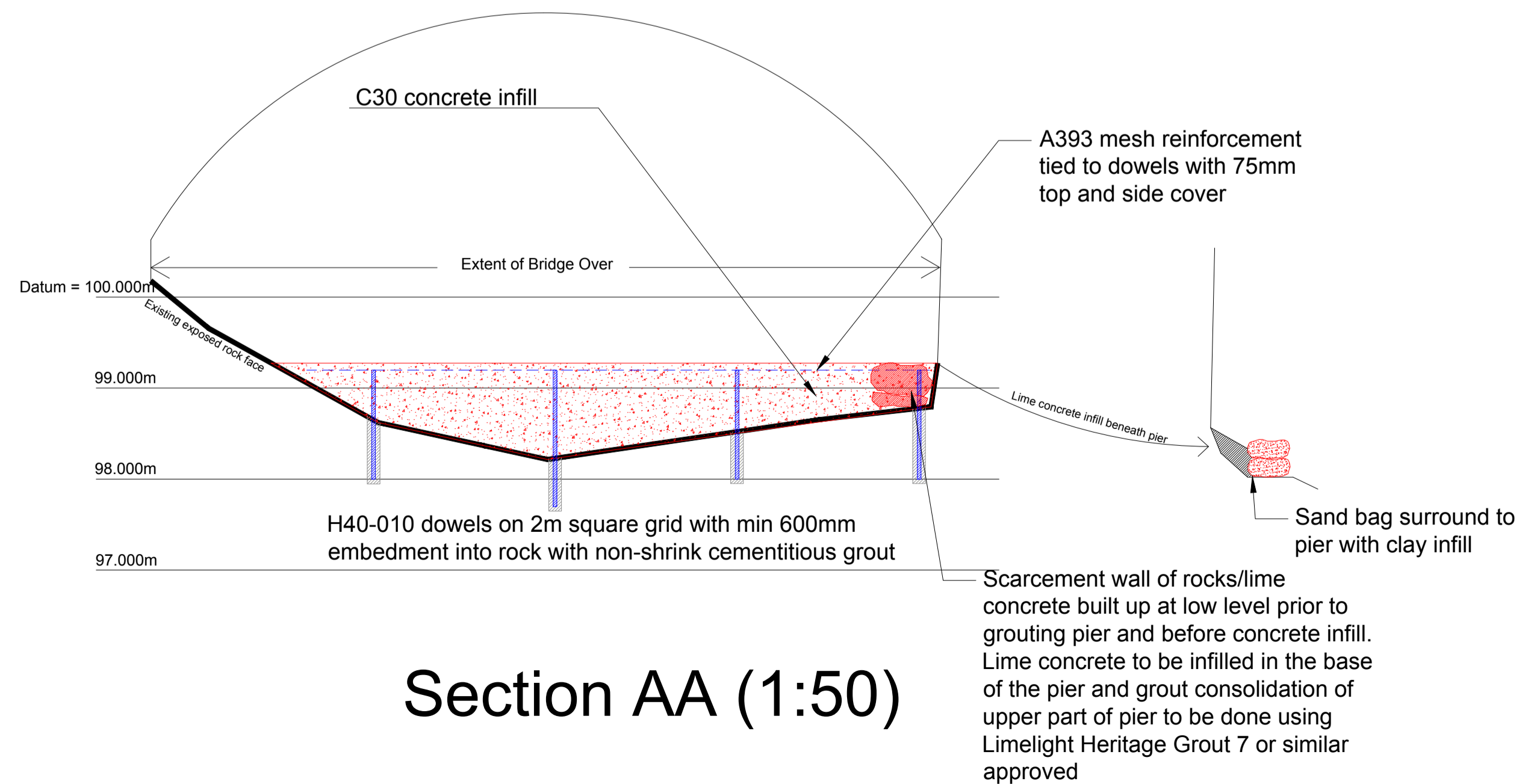

Section AA (1:50)

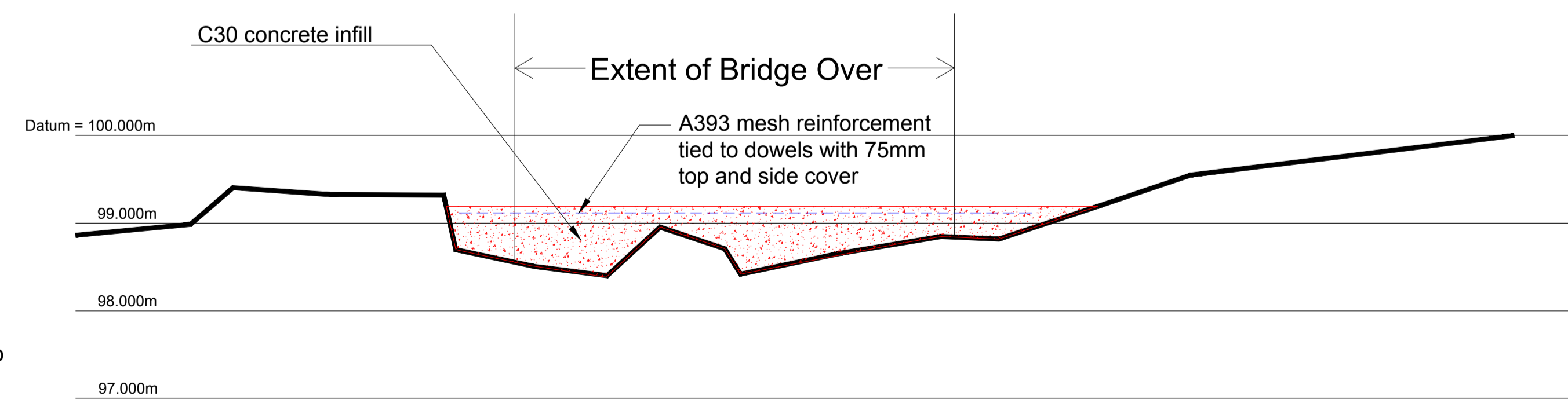

Section BB (1:50)

Residual Risks	
1.	Working in or adjacent to flowing water / potentially high flows
2.	Lifting and moving of heavy rock armour
3.	Working with cement and risk of contamination

Revisions:
 05/08/2016 Rev A- Changes in methodology and details (By FN)
 08/08/2016 Rev B- Changes in methodology and details (By FN)

Contains Historic Environment Scotland, Ordnance Survey and Aerial Imagery Data
 © Historic Environment Scotland © Crown copyright and database rights 2016
 Ordnance Survey (100059703) © Getmapping

Ordnance Survey Data
 You are permitted to use this data solely to enable you to respond to, or interact with, the organisation that provided you with the data. You are not permitted to copy, sub-licence, distribute or sell any of this data to third parties in any form.



MONUMENT	Invercauld Bridge
PROJECT	Scour Protection Works Concrete Infill Details



PROJECT DRAWING NUMBER	EDS.4.1.29/03		
SCALE	as shown @ A1	ENGINEER	Kashif Ashraf
DATE	19/07/2016	DRAWN BY	KA
ARCHIVE NUMBER		REVISION	B